

ALL LIDS MARKED "WATER"
UNLESS OTHERWISE SPECIFIED,
WITH CORED HANDHOLE

1220 mm (4')
CAST IRON
TOP PIPE
w/FLANGE

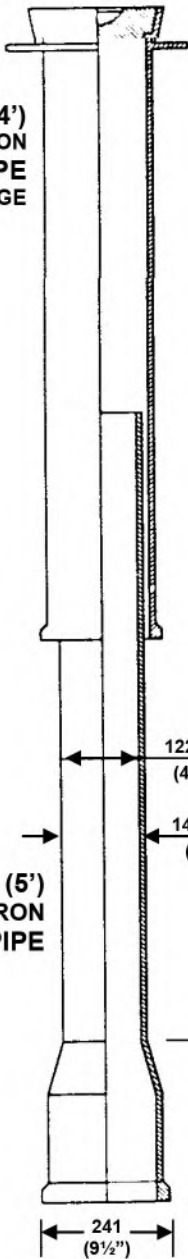

1524 mm (5')
CAST IRON
BOTTOM PIPE

50mm (2") TOP OPERATING NUT
WITH STONECATCHER FLANGE



25mm (1")
M.S. SQUARE
OPERATING ROD
STANDARD 2032mm (6'8")
AVAILABLE TO
6100mm (20')

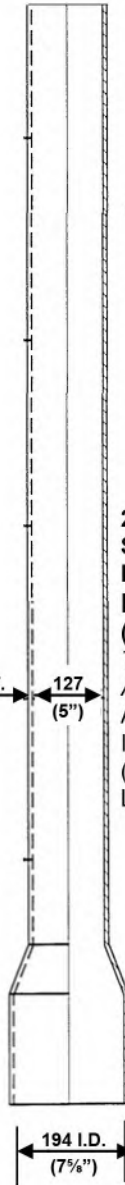

2438mm (8')
SCHD 40
P.V.C.
BOTTOM PIPE
(OPTIONAL)
TO BE FIELD CUT
AS REQUIRED
ALSO AVAILABLE
IN 3050 AND 3660
(10' AND 12')
LENGTHS

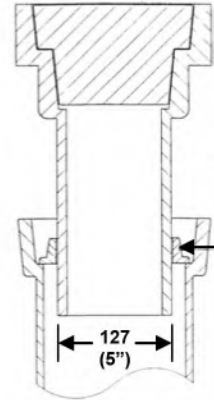

LOCKING
COLLAR
w/3 SET
SCREWS,
-OR-
RUBBER
COLLAR
WITH SS
STRAP

TOP EXTENSION
300, 600, or 900mm
(1', 2', or 3')

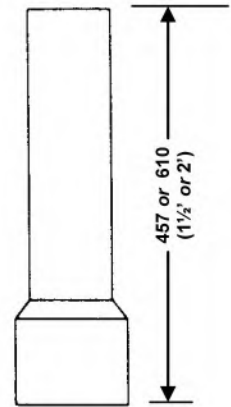

INTERMEDIATE
EXTENSION
(CAST IRON)

BOTTOM NUT WITH
50mm (2") CORED HOLE



SPECIFICATIONS:

THE CASTINGS SHALL BE TRUE TO PATTERN AND FREE FROM CRACKS, GAS HOLES, FLAWS AND EXCESSIVE SHRINKAGE. SURFACES OF THE CASTINGS SHALL BE FREE FROM BURNT ON SAND AND SHALL BE REASONABLY SMOOTH. RUNNERS, RISERS, FINES AND OTHER CAST ON PIECES SHALL BE REMOVED. IN OTHER RESPECT THE CASTINGS SHALL CONFORM TO WHATEVER POINTS MAY BE AGREED UPON BETWEEN THE MANUFACTURER AND THE ENGINEER. UPON REQUEST OF THE ENGINEER THE MANUFACTURER SHALL BE PREPARED TO CERTIFY THAT HIS PRODUCT CONFORMS TO THE REQUIREMENTS OF A.S.T.M. DESIGNATION A-48.



TYPE "A" (SLIDING)

VALVE BOX

ALL LIDS MARKED "WATER"
UNLESS SPECIFIED
OTHERWISE, WITH
CORED HANDHOLE,
MADE OF DUCTILE IRON

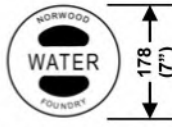

TOP PIPE
600mm, 900mm,
or 1200mm
(2, 3, or 4 ft.)

SPECIFICATIONS:

THE CASTINGS SHALL BE TRUE TO PATTERN AND FREE FROM CRACKS, GAS HOLES, FLAWS AND EXCESSIVE SHRINKAGE. SURFACES OF THE CASTINGS SHALL BE FREE FROM BURNT ON SAND AND SHALL BE REASONABLY SMOOTH. RUNNERS, RISERS, FINS AND OTHER CAST ON PIECES SHALL BE REMOVED. IN OTHER RESPECT THE CASTINGS SHALL CONFORM TO WHATEVER POINTS MAY BE AGREED UPON BETWEEN THE MANUFACTURER AND THE ENGINEER. UPON REQUEST OF THE ENGINEER THE MANUFACTURER SHALL BE PREPARED TO CERTIFY THAT HIS PRODUCT CONFORMS TO THE REQUIREMENTS OF A.S.T.M. DESIGNATION A-48 (CAST IRON), OR A-536 (DUCTILE IRON).

BOTTOM PIPE
900mm, 1200mm, or
1500mm (3, 4, or 5 ft.)

**BONNET,
MADE OF
DUCTILE IRON**

ANTI-ROTATION LUGS



**50mm (2") TOP OPERATING
NUT WITH STONECATCHER
FLANGE**

**25mm (1") M.S. SQUARE
OPERATING ROD**
STANDARD 2032mm (6'8"),
AVAILABLE TO 6100mm (20')

**INTERMEDIATE EXTENSION
FOR EXTRA DEEP BURY -
BOTTOM PIPE WITH
BELL REMOVED, AND
SPECIAL COUPLING
WITH 8 SET SCREWS**

TOP EXTENSION
450mm, 600mm, or 900mm
(1½, 2, or 3 feet)

**BOTTOM NUT WITH
50mm (2") CORED HOLE**



TYPE "B" (THREADED)

VALVE BOX

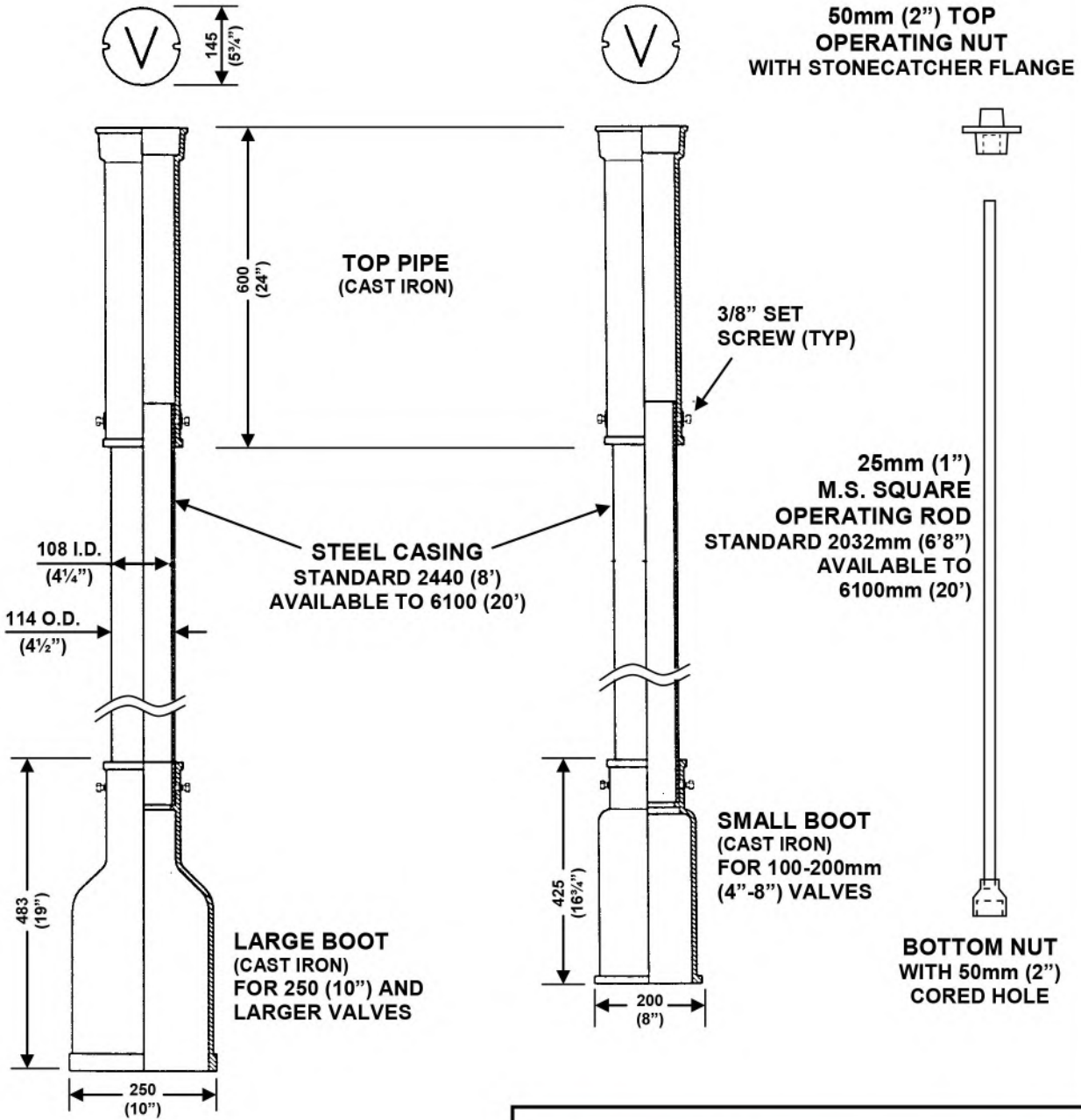

SPECIFICATIONS:

THE CASTINGS SHALL BE TRUE TO PATTERN AND FREE FROM CRACKS, GAS HOLES, FLAWS AND EXCESSIVE SHRINKAGE. SURFACES OF THE CASTINGS SHALL BE FREE FROM BURNT ON SAND AND SHALL BE REASONABLY SMOOTH. RUNNERS, RISERS, FINS AND OTHER CAST ON PIECES SHALL BE REMOVED. IN OTHER RESPECT THE CASTINGS SHALL CONFORM TO WHATEVER POINTS MAY BE AGREED UPON BETWEEN THE MANUFACTURER AND THE ENGINEER. UPON REQUEST OF THE ENGINEER THE MANUFACTURER SHALL BE PREPARED TO CERTIFY THAT HIS PRODUCT CONFORMS TO THE REQUIREMENTS OF A.S.T.M. DESIGNATION A-48.



**TYPE "C" (SLIDING)
WITH STEEL CASING CENTER PIECE**

VALVE BOX

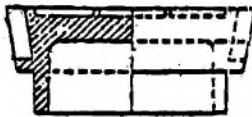
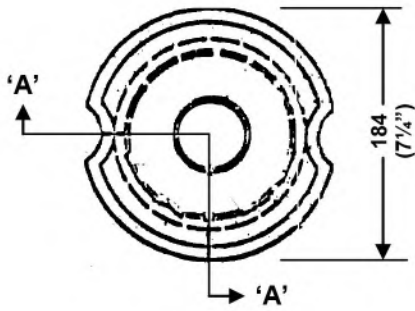

PLUG
SECTION 'A-A'
- ALSO AVAILABLE IN
LOCKING STYLE -

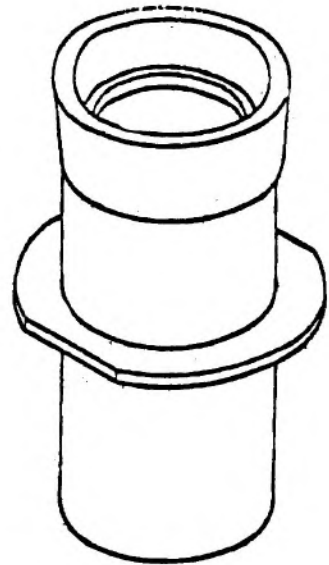

**TO BE USED WITH
150mm (6") PVC PIPE
AS THE BOTTOM SECTION**

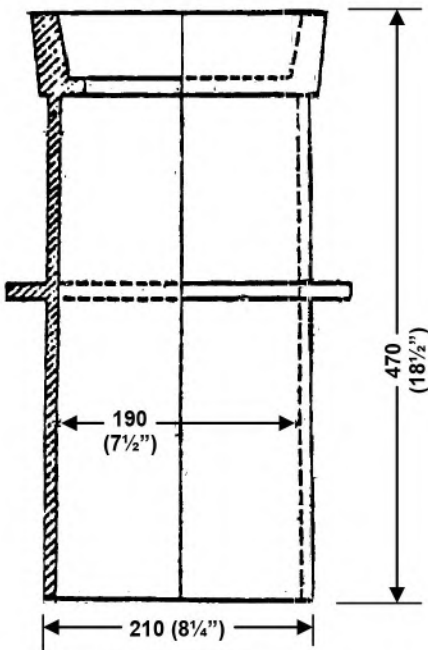

**TOP PIPE
SECTION 'B-B'**

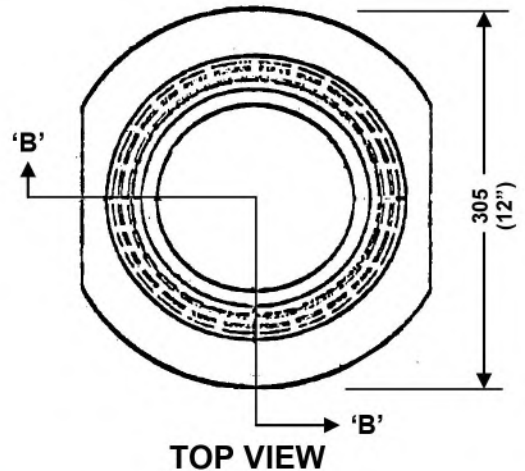

TOP VIEW

SPECIFICATIONS:

THE CASTINGS SHALL BE TRUE TO PATTERN AND FREE FROM CRACKS, GAS HOLES, FLAWS AND EXCESSIVE SHRINKAGE. SURFACES OF THE CASTINGS SHALL BE FREE FROM BURNT ON SAND AND SHALL BE REASONABLY SMOOTH. RUNNERS, RISERS, FINNS AND OTHER CAST ON PIECES SHALL BE REMOVED. IN OTHER RESPECT THE CASTINGS SHALL CONFORM TO WHATEVER POINTS MAY BE AGREED UPON BETWEEN THE MANUFACTURER AND THE ENGINEER. UPON REQUEST OF THE ENGINEER THE MANUFACTURER SHALL BE PREPARED TO CERTIFY THAT HIS PRODUCT CONFORMS TO THE REQUIREMENTS OF A.S.T.M. DESIGNATION A-48.



NELSON TYPE

VALVE BOX